



Clean Air

Fume Cupboards

The Science of Fume Containment



PPX Ducted Polypropylene Plastic Fume Cupboard



ISO 9001
ISO 14001
ISO 45001

 **MADE IN
BRITAIN**



Optimised corrosion-proof design for chemical resistance and operator safety

The PPX fume cupboard is constructed almost entirely from copolymer polypropylene. It is a robust, high-performance solution designed to meet stringent safety and durability standards.

The minimal metal components are securely isolated and limited to parts of the electrical sockets, control panel, lighting, and associated wiring and services. For maximum strength and longevity, the PPX fume cupboard is manufactured using a combination of folding, and plastic welding and bolting techniques, ensuring a stable, long-lasting structure.

Optimised through Computational Fluid Dynamics (CFD), the PPX design delivers superior containment for enhanced operator safety. Comparative testing in line with BS EN14175-3 demonstrates that the PPX achieves excellent containment properties, matching those of standard metal construction fume cupboards. It meets the highest classification for “Good achievable containment results – Higher hazards, e.g. Research/Commercial”, as often required in research and commercial environments (at face velocity 0.4 m/s and above).

Polypropylene’s inherent chemical resistance makes the PPX fume cupboard ideal for applications involving large quantities of organic solvents and most acids and bases, excluding strong oxidising acids such as nitric acid. This makes the PPX a highly reliable and chemically resistant choice for demanding laboratory environments.

The PPX comes with a mobile, polypropylene acid storage cupboard sized to fit below the chamber.

All this as Standard

Not every fume cupboard is supplied with as many features as standard as a Clean Air fume cupboard! Always check you’re comparing like with like.

- Made almost entirely of plastic materials, with maximum chemical resistance
- Carcass constructed from copolymer polypropylene
- Chemically resistant twin skin shell with stiffening ribs
- No exposed metal components
- Interior liners & baffles from polypropylene
- Worktop from polypropylene
- 6mm thick polycarbonate sliding sash
- Sash stop device at 400mm or 500mm for operator safety
- Flush membrane control panel
- Visual and audible low airflow alarm
- Electrics pre-wired to a 5-way consumer unit complete with built-in RCBOs & MCBs
- Polypropylene hinged lower aerofoil for cable entry
- Polypropylene tissue guards to prevent debris from being drawn into the extract ductwork
- Polypropylene vented storage cupboard
- Lift-out upper panel for quick, easy maintenance and inspection

Controls

- Advanced programmable control panel
- Alarms for air velocity, sash high, and fan operation
- Alarm levels reported on the display
- BACnet MS/TP and Modbus RTU available

Customise to your application

- Variable Air Volume (VAV) technology for energy efficiency or Constant Air Volume (CAV) designs
- Integrated fume scrubber - rear-mounted, close coupled, packed bed design with optional automatic dosing system
- Automatic fire suppression system (dry powder, CO₂, or foam)
- Rear-mounted polypropylene scaffold bosses and frames
- Broen, Vacuubrand and Spectrolab water and gas services
- Drip cups and sinks
- Interior liners & baffles from Trespa® TopLab® BASE or PLUS solid grade laminate
- Polycarbonate sash for use with HF
- Worktop from cast epoxy
- Power sockets, standard single socket outlets, industrial socket outlets, data sockets and emergency stop button
- Standard steel storage cupboards, fire-rated solvent storage cupboards or vac pump cupboards
- Pass through ports in side panels
- Alternative colours: Beige, Dark Grey, Black (standard colour is White)
- Bespoke and non-standard sized units are available on request – tell us your preferred dimensions
- Optional dual coloured internal light

Servicing

A Clean Air service includes much more than simply face velocity testing – ask us for details

- Full service and maintenance packages available
- Options to lock in prices
- Highly trained test engineers
- Never over-run your test date with our free test scheduling service
- Most makes and models of fume cupboard serviced

PPX Ducted Polypropylene Plastic Fume Cupboard Technical Specification



The PPX fume cupboard comes in standard sizes and can also be manufactured to your bespoke size requirements – just ask us for more information

Dimensions PPX Ducted Polypropylene Plastic

External width	1000mm	1200mm	1500mm	1800mm	2000mm
External height	2370mm				
External depth	900mm				
Chamber width	700mm	900mm	1200mm	1500mm	1700mm
Chamber Height	1270mm (Worktop to Soffit)				
Chamber depth	665mm (Sash to Baffle)				
Sash Opening Width	700mm	900mm	1200mm	1500mm	1700mm
Max Sash Opening Height	695mm				

Extract Volumes

	Face Velocity	1000mm	1200mm	1500mm	1800mm	2000mm
Extract Volumes at a 400mm sash opening	0.3m/s	0.103m ³ /s	0.124m ³ /s	0.155m ³ /s	0.194m ³ /s	0.220m ³ /s
	0.35m/s	0.121m ³ /s	0.145m ³ /s	0.181m ³ /s	0.226m ³ /s	0.256m ³ /s
	0.4m/s	0.138m ³ /s	0.165m ³ /s	0.207m ³ /s	0.258m ³ /s	0.293m ³ /s
	0.5m/s	0.172m ³ /s	0.207m ³ /s	0.258m ³ /s	0.323m ³ /s	0.366m ³ /s
Extract Volumes at a 500mm sash opening.	0.3m/s	0.129m ³ /s	0.155m ³ /s	0.194m ³ /s	0.242m ³ /s	0.275m ³ /s
	0.35m/s	0.151m ³ /s	0.181m ³ /s	0.226m ³ /s	0.283m ³ /s	0.320m ³ /s
	0.4m/s	0.172m ³ /s	0.207m ³ /s	0.258m ³ /s	0.323m ³ /s	0.366m ³ /s
	0.5m/s	0.215m ³ /s	0.258m ³ /s	0.323m ³ /s	0.404m ³ /s	0.458m ³ /s

PPX Ducted Polypropylene Plastic Fume Cupboard Technical Specification

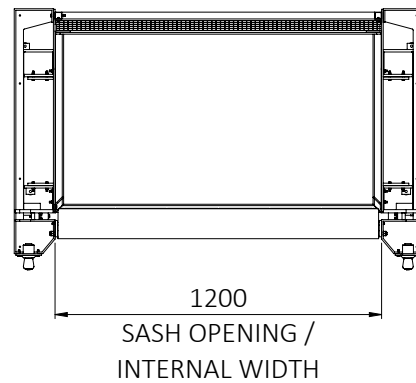
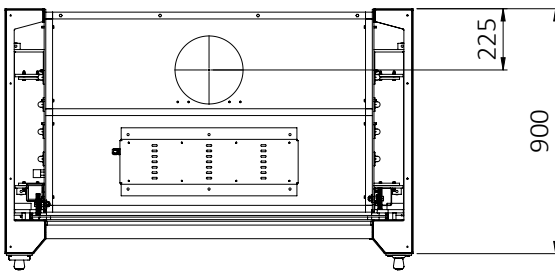
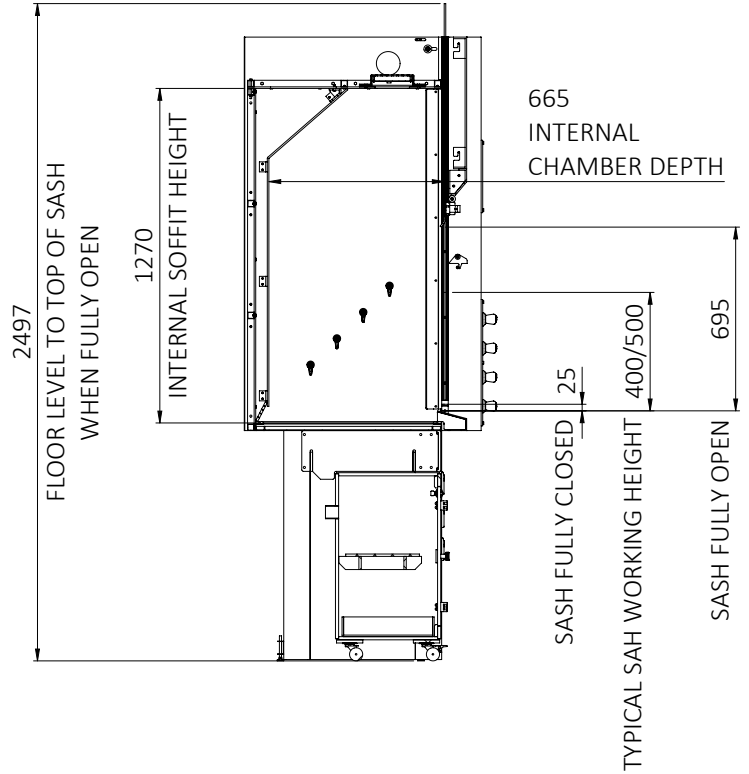
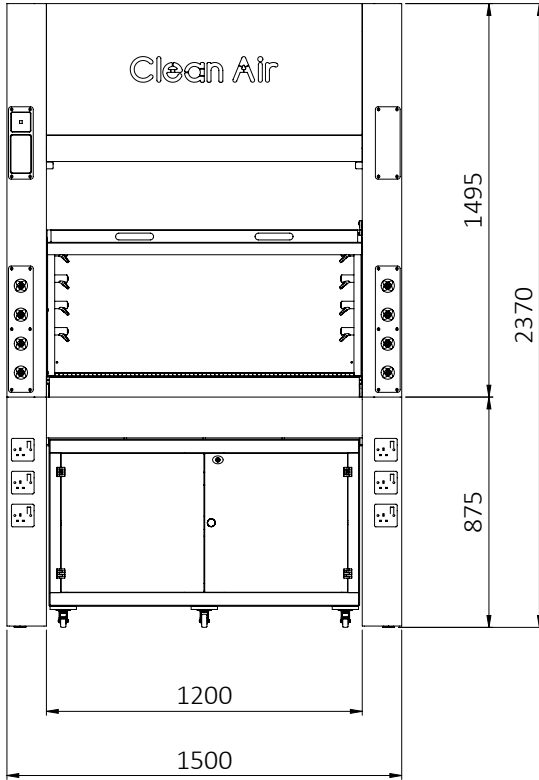

01204 572900
sales@cleanairltd.co.uk
www.cleanairltd.co.uk

The contents of this document are the property of Clean Air Ltd and are copyright. Clean Air Ltd reserves the right to change any part of this document without notice at any time. While Clean Air makes every reasonable effort to ensure that this material is accurate, Clean Air accepts no liability for technical inaccuracies or typographical errors.